

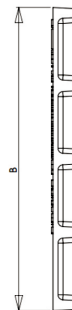

MUNICIPAL CASTINGS | DUCTILE IRON

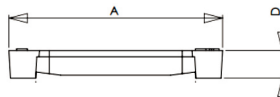
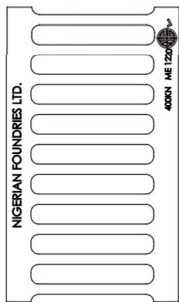
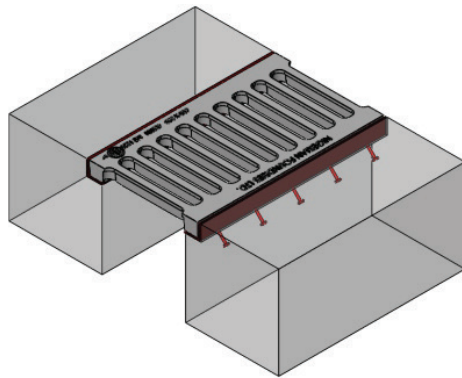

PRODUCT INFORMATION

HEAVY DUTY
CHANNEL GRATINGS

FEATURES AND BENEFITS

- Made from Ductile iron as per International Standard ASTM A536-84(2014)
- For use in carriageway of roads, (including pedestrian streets), hard shoulders and parking areas for all types of road vehicles.
- Efficient grates for large water clearing capacity
- Suitable for fast moving vehicular traffic.
- Easy to Lift and Painted.
- All Products are proudly made in Nigeria with 100% Local Content.

HEAVY DUTY CHANNEL RATINGS



APPLICATION



GROUP



BS EN 124 CLASS



TEST LOAD

SPECIFICATIONS

PRODUCT CODE	(A)mm	(B)mm	CLEAR OPENING (C)mm	HEIGHT OF GRATE (D)mm	ANGLE IRON SIZE
CHA005	250	600	160	45	50 X 50
CHA006	350	600	260	45	50 X 50
CHA140	300	600	210	45	50 X 50
CHA049	400	600	310	45	50 X 50
CHA144	500	700	410	45	50 X 50

HEAD OFFICE & FACTORY

LYN SON CHEMICAL AVENUE, KM-38 ABEOKUTA-LAGOS EXPRESSWAY,
SANGO-OTA, OGUN STATE. NIGERIA. +234 807 089 0883 | 080 8927 4521
WWW.NIGERIANFOUNDRIES.COM

GET A QUOTE

+234703 475 9821

sales@nigerianfoundries.com